

# UNIVERSAL REGISTRATION DOCUMENT 2022

**INCLUDING THE ANNUAL FINANCIAL REPORT  
AND THE INTEGRATED REPORT**



This Universal Registration Document has been filed on February 28, 2023 with the AMF as competent authority under Regulation (EU) 2017/1129, without prior approval pursuant to Article 9 of the said regulation. The Universal Registration Document may be used for the purposes of an offer to the public of securities or admission of securities to trading on a regulated market if completed by a securities note and, if applicable, a summary and any amendments to the Universal Registration Document. The whole is approved by the AMF in accordance with Regulation (EU) 2017/1129. The English language version of this Universal Registration Document is a free translation from the original, which was prepared in French. All possible care has been taken to ensure that the translation is an accurate representation of the original. However, in all matters of interpretation of information, views or opinions expressed therein the original language version of the document in French takes precedence over this translation.

*This Document is a reproduction of the official version of the Universal Registration Document including the 2022 Annual Financial Report prepared in accordance with the European Single Electronic Format (ESEF) and filed with the AMF, available on the website [www.faurecia.com](http://www.faurecia.com).*



This integrated report enables all stakeholders to better understand the company's vision and strategy for profitable growth. FORVIA's business model is focused on creating value for all its stakeholders, in terms of both financial and non-financial performance over the short and long term.

FORVIA's mission is to pioneer technology for mobility experiences that matter to people. This year we have driven a number of historic changes making us a stronger, more resilient and more future-focused Group.

This document is the introductory chapter of Faurecia's 2022 Universal Registration Document. For further information please consult [www.faurecia.com](http://www.faurecia.com)

 / 2022 Universal Registration Document



Foreword from Michel de Rosen,  
Chairman of the Board, Faurecia 04

Interview with Patrick Koller,  
Chief Executive Officer, Faurecia 06

## The 10 assets of a new leader in the automotive industry

At the heart of megatrends	12
A broad technology offer	14
Driving a more sustainable future	16
People-first organization	18
The 7 <sup>th</sup> largest supplier worldwide	20
Accelerating our digital transformation	22
Expert-driven innovation	24
A valued partner for customers	26
Operational excellence	28
Robust risk management	30



## Behind and beyond future mobility

### ELECTRIFICATION AND ENERGY MANAGEMENT

A flexible partner for zero emissions mobility	38
Scaling up hydrogen mobility	38
Rethinking next generation electric vehicles	40

### SAFE AND AUTOMATED DRIVING

Vision systems for safer roads	44
Intelligent lighting for better interactions	46
By-wire control: the future of steering and braking	48

### DIGITAL AND SUSTAINABLE COCKPIT EXPERIENCES

Connected services: safe, affordable, sustainable	52
Modular and circular thinking by design	54
Sustainable material innovation	58

## Governance and Performance

An effective governance	58
FORVIA value creation model	62
2022 financial performance	64
2022 sustainability performance	68

## Foreword from Michel de Rosen, Chairman of the Board, Faurecia



**“In 2022,  
we engaged  
in a rapid  
and profound  
transformation.”**

**For Faurecia, 2021 was the year of the spin off from Stellantis and the launch of our project to acquire HELLA. 2022 was the creation of FORVIA and the first year of Faurecia and HELLA getting to know and respect each other, working and creating value together for our customers and shareholders.**

Did Victor Hugo predict FORVIA would exist and become a leading global supplier for the automotive industry? As he was a great visionary, he might have.

We can be proud of the progress we have accomplished in just one year: the synergies identified during the acquisition have been confirmed; FORVIA's strategy, presented in November 2022 at our first joint Capital Markets Day has been welcomed by the markets; our expanded, diversified and industry-leading technology portfolio has already brought us new high-value-added contracts; the 2023 Consumer Electronics Show in Las Vegas enabled our customers to discover the strength of our combined innovation capabilities.

Sustainable development is in the DNA of both Faurecia and HELLA. It is a source of great pride that our Group's carbon net zero objective was approved in June by the highly demanding Science Based Targets initiative – a first in the automotive industry. In addition, FORVIA's first Sustainability Day in November 2022 showed the keen interest our stakeholders have in our sustainability actions.

These successes are the result of close and rigorous collaboration between Faurecia and HELLA teams, facilitated by a balanced governance structure, including a dedicated integration organization. This structure promotes smooth decision-making and efficient cooperation to build the new Group, while enabling Faurecia and HELLA – which remain independent and listed companies – to create value in their own interests and for all their stakeholders.

As part of the acquisition of HELLA, the Hueck and Roepke family, which held 60% of HELLA shares, became our largest shareholder. At Faurecia's Annual General Meeting in June 2022, our shareholders ratified the appointment of Dr. Jürgen Behrend to Faurecia's Board of Directors as a representative of the Hueck and Roepke family. His presence on our Board underlines the family's strong commitment to FORVIA's strategy and prospects. In February 2022, we also welcomed Judy Curran as an independent Board member. Judy brings us a remarkable automotive and technology expertise.

The acquisition of HELLA was a major operation for Faurecia. Make no mistake: our rapid deleveraging is now our top priority. In June, our successful €705 million capital increase represented a key step in the improvement of our capital structure. With the recent completion of further

# €705m

capital increase in  
June 2022

refinancing, we have reached a major milestone and are sending a strong signal to the markets.

Our medium-term POWER25 plan, combined with our €1 billion divestment program by the end of 2023, will enable us to continue to accelerate our deleveraging while creating the conditions for profitable and sustainable growth.

In 2022, Faurecia made a step change and engaged in a rapid and profound transformation. On behalf of the Board, I thank Faurecia's management for their leadership and the energy they have devoted to this large and complex project. I thank all our teams for their commitment and agility. I also thank our customers for their trust and our shareholders for the confidence they place in our Group in this new chapter of its development.

**“We can be proud of the progress we have accomplished in just one year.”**

## Interview with Patrick Koller, Chief Executive Officer, Faurecia



**“In a transforming industry, transformative companies are needed.”**

**Mobility transition**

**2022 started at full speed with the creation of FORVIA. Could you introduce the Group?**

The combination was a foundational milestone and I would first like to thank the Faurecia and HELLA teams for what we have achieved together since Day One, and the significant synergies already delivered. In a transforming industry, transformative companies are needed: as FORVIA, we are now the world's 7<sup>th</sup> largest automotive supplier. Our broad and balanced portfolio, reduced exposure to the internal combustion engine and strengthened geographic and customer reach with 80+ automakers, give us a leading edge to accelerate the mobility transition ahead. 157,000 talents from 43 countries will be instrumental in making it happen. One key achievement of the year was the definition of our shared mission: We pioneer technology for mobility experiences that matter to people.

**From the very first weeks FORVIA faced a complex environment...**

Absolutely, we were confronted with challenges soon after closing the deal – with the start of the war in Ukraine and COVID-related restrictions in China a few weeks later. Our industry had to adapt to a tough environment with inflation, stop-and-gos and volatile energy prices. This has impacted production, but our teams have showed incredible resilience to adapt, maintain performance and satisfy customer demand.

# A new scale

Uncertainty is likely to continue. Aligning our strategy with fast-growing automotive trends – electrification and energy management, safe and automated driving, and everything that contributes to mobility experiences within the car – helps us mitigate risk. We have taken a step change in scale and scope, and this is a powerful lever to manage the increased complexity in today's market.

## How will you capture the value of this new scale in the medium term?

FORVIA is targeting more than €30 billion in sales by 2025 – a figure that is to a very large extent already secured. This objective comes with a detailed action plan announced at our Capital Markets Day: POWER25. Faurecia and HELLA have defined ambitious targets and three common strategic priorities to make it happen: sales growth driven by innovation and sustainability; lower breakeven and enhanced profitability; and strong cash conversion and portfolio management to accelerate Group deleveraging. Faurecia has entirely refinanced the HELLA acquisition through an additional private placement,

and has achieved its divestment target of €1 billion by end of 2023 through the contemplated disposal transactions announced to date. This priority on deleveraging will bring our Group back to a net debit to EBITDA ratio of 1.5 by 2025. POWER25 includes actions to face the short-term headwinds of the coming year too, before worldwide automotive production starts resuming. Improving our profitability and competitiveness will also bring new opportunities in the coming years. We are already in motion shaping FORVIA as a sustainable mobility technology leader.

## Innovation will be key to achieve this ambition. How are you doing in that field?

FORVIA's bigger scale and scope allows us to go further in innovation. Our strategy is aligned with the megatrends shaping the mobility industry – with groundbreaking technologies for key automotive challenges of electrification, connectivity and sustainability. We are present everywhere with recognized expertise in sustainable materials, energy and weight saving, upgradability, recyclability, and circular economy design; in all geographies, including Asia; and for all types of customers. FORVIA's business in the premium vehicle segment, which features a concentration of innovative technologies, is increasing.



# €30bn

in sales by 2025

# Innovation

“We are already in motion shaping FORVIA as a sustainable mobility technology leader.”

FORVIA benefits from a global innovation ecosystem including academia and start-ups and that will soon engage communities of users to better understand what features people want to use and enjoy in their cars.

we were the first automotive industry company to receive the globally renowned Science Based Target initiatives (SBTi) certification, meaning that we will be carbon net zero by 2045.

# 2045

carbon net zero

#### What's your outlook for the next few years?

In 2022 Faurecia's transformative acquisition of HELLA made FORVIA a new global leader poised for profitable growth and strong value creation. Together we are better equipped to navigate potential market headwinds, through our presence in fast-growing segments. I am confident in our ability to deliver on our ambition and to make mobility more sustainable and affordable for everyone, thanks to continued support from all our employees, customers, suppliers and partners. I would like to thank them for their commitment to FORVIA's success.

## Carbon net zero

#### How do you combine innovation with sustainability?

We address mobility needs with solutions that benefit our customers and consumers, but also the planet. For several years Faurecia and HELLA have been rethinking our technologies and how they are produced. In 2022,

We are working on concrete intermediate targets across our operations and products – for today, 2025 and 2030. In 2022, at FORVIA's first Sustainability Day we launched MATERI'ACT to accelerate the development of sustainable, low CO<sub>2</sub> materials, targeting €2 billion sales by 2030. With new materials, new architectures and eco-design for a more circular economy mindset, we will help automakers achieve their net-zero goals too.

# €2bn

in sales of sustainable, low CO<sub>2</sub> materials by 2030



**We pioneer  
technology**  
for mobility  
experiences  
that matter  
to people.

**The 10 assets  
of a new leader in the  
automotive industry**



## 01

# At the heart of megatrends

**Megatrends are radically shaping future mobility needs. In a rapidly transforming automotive industry, FORVIA brings the technology insights and capabilities to enable this transition.**

Mobility is evolving fast, impacted by global technology and automotive trends. Societal changes like generational shifts, population growth, urbanization and evolving consumer expectations change the way we access and use mobility. For example, new technologies enable innovative ways to exploit data and AI. Materials science, and alternative energy solutions result in often radically different needs for future products. The automotive industry is heavily impacted by trends such as electrification; automated driving; connected, personalized and shared mobility as well as sustainability.

FORVIA works at the heart of this transformation. Our strategy, aligned with these major trends, drives the way we design experiences and meet future mobility needs, through safe, affordable and sustainable solutions. This means taking into account changing attitudes toward mobility, and being open to develop new business models and invest massively in new technologies. As a sustainable mobility technology leader, we are ideally placed to anticipate and enable the mobility transition.

Mobility is at the heart of people's lives and of what matters to them: moving freely, caring for the planet, in their own way. That's why FORVIA pioneers technology for mobility experiences that matter to people.



## Electrification

A seismic shift for the automotive industry is the electrification of the powertrain with the goal of zero emissions mobility. Automakers have committed to switching to electric vehicles within 10 to 15 years, and this change is moving at different speeds across the world. FORVIA provides electromobility solutions adapted to different use cases and develops technologies and vehicle architectures to enable the transition toward zero emissions.



## Vehicle as driver

Smarter vehicles are already making our roads safer through onboard intelligence and assisted driving features. The progress from automated driving toward autonomous mobility applications has to ensure full safety for all road users in all driving situations. FORVIA's strength in safety critical systems allows us to take a leading role in this transition.

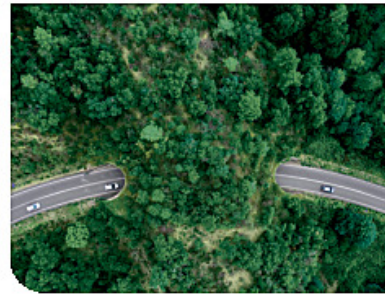

## Tackling climate change

The goal of making vehicles more sustainable is fundamentally reshaping how we design for lifetime use, reuse and recycling. FORVIA is rethinking mobility with a circular mindset, innovating in ultra-low CO<sub>2</sub> emission materials, creating lightweight and energy-saving technologies and developing new ways to extend product life. By 2045 we aim to be carbon net zero in both our operations and products.



## Human-centered

There is an ongoing change in what customers expect from their journey in a car. Technology innovations, digitalization and the power of data are enabling multiple ways to personalize the mobility experience. From passenger comfort and well-being to seamless connectivity to information and entertainment, at FORVIA we are helping to create a connected, versatile and customized space adapted to each individual.



## 02

# A broad technology offer

**A worldwide presence, Business Groups providing advanced technologies in fast-growing automotive domains... FORVIA is leading the development of solutions that will enable the next generation of mobility.**

By combining the complementary strengths of Faurecia and HELLA, FORVIA has a comprehensive technology offer across our Business Groups of Interiors, Seating, Electronics, Clean Mobility, Lighting and Lifecycle Solutions.

This diversified and balanced portfolio is guided by a strategy that is fully aligned with key automotive trends and key growth drivers in our industry:

- electrification and energy management: technologies that are helping our industry transition to ultra-low and zero-emissions mobility for all vehicle types.

- safe and automated driving: technologies that significantly increase safety and comfort in driving.

- digital and sustainable cockpit experiences: technologies designed to enhance the connected onboard experience and promote well-being.

FORVIA's technology vision is highly integrated: we combine individual hardware and software components into systems that deliver safe, sustainable, advanced and customized mobility. FORVIA is also a major force in electronics and software, which are increasingly critical components in current and future vehicles.

# Our product portfolio

## Lighting

- Front headlamps
- Rear headlamps
- Car body & interior lighting

## Interiors

- Instrument & door panels
- Center consoles
- Cockpit modules

## Lifecycle Solutions

- Parts & accessories for the independent aftermarket as well as special original equipment
- Diagnostic services for testing & repair

## Electronics

- Automated driving
- Cockpit electronics
- Energy management
- Lighting/body electronics
- HMI/displays
- Sensors & actuators

## Seating

- Complete seats
- Mechanisms & frames
- Safety & comfort solutions

## Clean Mobility

- Ultra-low emissions solutions for passenger & commercial vehicles
- Zero-emission solutions for battery & fuel cell vehicles



## 1 in 2 vehicles

on the road today is equipped with FORVIA products



## 03

# Driving a more sustainable future

**FORVIA has a key role to play in the sustainable transition of the automotive industry. Core to this is our own transition to CO<sub>2</sub> net zero.**

Our journey to net zero is well underway, with three major milestones that are aligned across Faurecia and HELLA: by 2025, we want to be CO<sub>2</sub>-neutral across all operations (scopes 1 and 2); by 2030, we will reduce scope 3 emissions by 45%; and we will achieve net zero by 2045.

These targets are integral to our corporate strategy. That's why we were the first automotive group in the world to have our net zero ambitions validated by the Science Based Targets initiative, a partnership between the Carbon Disclosure Project (CDP), the United Nations Global Compact, the World Resources Institute and the World Wildlife Fund, with the most demanding assessment standards.

To achieve these milestones, we are already using less, using better and using longer – working with fewer virgin materials, using materials more efficiently to save resources, and creating products that last longer and are easier to recycle, supporting circularity. In addition, we have partnered with ENGIE, EDP and Schneider to enact and accelerate energy reduction strategies, generate green power at our own sites, and purchase renewable energy, for instance, from European wind farms.

These actions are already creating concrete results, with our pioneering development of green steel in seating; our partnership with Veolia on recycled materials; and the launch of our sustainable materials brand, MATERI'ACT.

# Our key sustainability indicators

## Our road to net zero

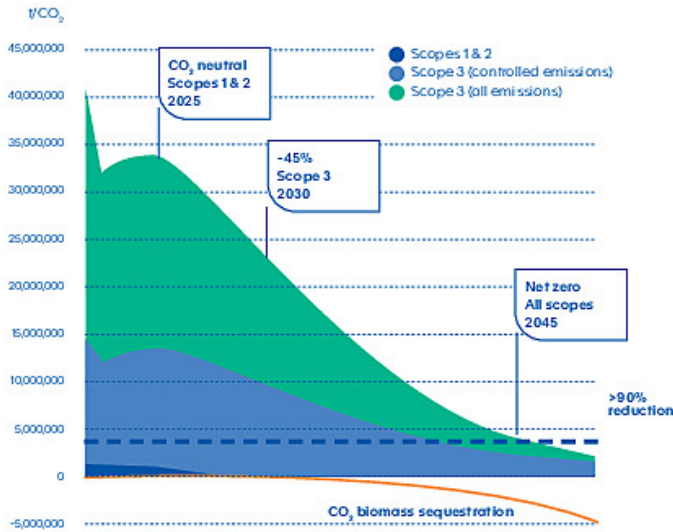

## Greener energy

- 130ha**  
 of solar panels on 150 sites in 22 countries with capacity of ~7% of the Group's total electricity consumption
- 27**  
 offsite wind turbines in Sweden covering 2/3 of FORVIA's European electricity needs

**€100M**  
invested in energy reduction by 2023

**30%**  
of vehicle interiors to be recycled plastic by 2025

**4,800**  
managers' variable compensation dependent on sustainability targets\*  
\*Faurecia data.

## Sustainability ratings

**SUSTAINALYTICS**  
Low Risk

**CDP**  
A- for Climate, B for Water, A for Supplier Engagement

**MSCI**   
BBB

**ecovadis**  
in the top 1% of our category

**EURONEXT**  
Listed on Euronext CAC 40 ESG Index

**ISS ESG**   
C



## 04

# People-first organization

**People are at the heart of our mission, whether it's employees, customers or communities. FORVIA focuses on recruiting the best talents, offering them attractive development opportunities and promoting diversity within its teams. Through the FORVIA Foundation, the Group supports the solidarity initiatives of its employees.**

In a challenging labor market, FORVIA maintained a high level of recruitment, with Faurecia hiring over 13,000 permanent staff in 2022. The use of artificial intelligence has helped to optimize candidate sourcing. In line with our ambition to become a sustainable mobility tech leader, the Group has continued to strengthen its activity in sectors such as electronics, software and sustainable materials. Another focus has been female talents: 35% of the managers and engineers Faurecia recruited in 2022 are female.

To attract and retain the best talents, FORVIA offers dynamic and varied career paths. A priority is given to internal promotion – based on performance, potential and the

motivation to progress. Regular reviews ensure the identification and individualized follow-up of high potentials. To prepare its future, the Group also pays very close attention to finding and recruiting its leaders of tomorrow and offering them a tailored and diversified career path.

FORVIA fosters the development of all talents through challenging jobs and lifelong learning with the aim of helping them grow and develop in their career and ensure their employability in a constantly changing industry. Thanks to FORVIA University, in 2022 each Faurecia employee received an average of 22.9 hours of training. By 2030, each FORVIA employee will receive 25 hours of training. Our online Learning Lab, accessible to all including HELLA teams since this year, offers more than 2,000 training courses in 23 languages. 2022 saw a marked increase in new formats and modules enabling Faurecia and HELLA employees to discover their respective business activities.



## FORVIA for me

At the end of 2022 FORVIA launched a new employer branding to enhance the Group's attractiveness and reflect its new mission "We pioneer technology for mobility experiences that matter to people." It focuses on the positive impact of people's contributions and is currently being deployed at job fairs and in social media campaigns.

## An inclusive company

In 2022, FORVIA intensified its diversity initiatives: training to promote better understanding of diversity benefits, development of targeted recruitment, coaching and mentoring programs for female employees and highlighting women's careers in our communications. FORVIA also continues to build an inclusive workplace that offers equal opportunities to all and fights against all forms of discrimination.

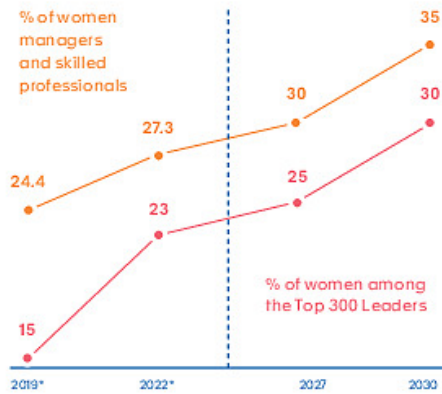

\* Faurecia data. The consolidation of FORVIA Group data is ongoing.



**Camille Pireyre,**  
Electronics,  
Technical Project  
Leader, Faurecia

"I enjoy the wide range of interactions my job offers: customers, suppliers, our plant in Hungary and my team – 20 people across France, Europe and India. Despite diverse technical backgrounds and cultures, we share a common goal to deliver a product that fulfills customers' expectations. The diversity of interlocutors ensures good debates, sometimes more complex, but often with much better results!"

## A committed Foundation

Created in 2020, the Faurecia Foundation expanded to HELLA this year, becoming the FORVIA Foundation. It supports projects with a strong social impact linked to education, mobility and the environment. In 2022 the Foundation funded 21 projects led by employees from 12 countries. To support people in Ukraine, the Foundation donated €500,000 and matched €25,000 raised in internal fundraising with a further €25,000.



## 05

# The 7<sup>th</sup> largest supplier worldwide

**Strengthening its reach by combining the international footprints of Faurecia and HELLA, FORVIA is leveraging this expanded and global presence to reinforce proximity with clients and capture growth in specific geographies and market segments.**

FORVIA has a highly international network of production plants, R&D and technical centers, logistics sites, and sales offices across 43 countries. This comprehensive global footprint covers key automotive markets in Europe, North, Central and South America, and across Asia. We continue to strengthen customer proximity by providing technical and production expertise locally and accelerating capacity to meet growing demand for innovative solutions, especially for different vehicle categories. By carefully balancing our activity across key

geographies, high content vehicle segments and share of business with customers, we reduce risk at the same time as leveraging growth opportunities.

### 30 years in China

In 2022 Faurecia and HELLA celebrated 30 years in China. Over three decades, both have actively invested and expanded their scope of activities. Today FORVIA has created strong partnerships with leading automakers and suppliers in China as well as with Chinese start-up automotive companies, supporting across its business areas of Interiors, Seating, Clean Mobility, Electronics and Lighting.

# Our global presence



**291**

plants



**76**

R&D centers



**43**

countries



**157,000**

employees



## Balanced sales by geography

45%  
Europe,  
Middle East,  
Africa



28%  
Americas

27%  
Asia (21% China)

## FORVIA in China



**95**

sites

**27,700**

employees



## 06

# Accelerating our digital transformation

**FORVIA is leveraging digitalization to significantly improve its global competitiveness - from scaling up an ambitious data analytics program along the entire value chain, collaborating with promising start-ups to rolling-out innovative digital ways of working...**

With three main priorities to accelerate its digital transformation, FORVIA is increasing its efficiency and competitiveness to deliver results to both businesses and people. It's a strategy driven from the Executive Committee level and builds on the Group's strong IT organization and robust cybersecurity.

One key lever is data, which brings insights, agility and speed. A transversal team of data specialists in France, Germany and India uses powerful AI and analytics tools to leverage data for better decision-making across the value chain. Supported by partners such as

Palantir and Accenture, this group-wide program informs optimized decisions and actions across manufacturing, R&D, sales, program and financial management.

Digital co-innovation brings FORVIA together with the most promising start-ups based on identified business needs and also enables the best possible collaboration between FORVIA and start-ups through a dedicated catalyst function.

Digital ways of working require smart tools and applications. One example is "WelcomeonBoard" – a digital onboarding program linked to learning platforms, customizing the experience to an individual's profile. Another is FORVIA's virtual meeting rooms where internal designers, engineers and customers can visualize, advance and review products in virtual reality to go faster in development and foster global collaboration.

# Transversal digitalization

## Digital value chain

Leverage data along the entire value chain to inform better decision-making and execution

01



02

## Digital co-innovation

Differentiate by being close to promising start-ups and by challenging existing business models



## The Drivery

FORVIA has built up and is running one of the fastest growing marketplaces of mobility innovation in Europe. The Drivery in Berlin, Germany, brings together all kinds of mobility innovators and supports the important ideas phase when start-ups need to find funding, their initial customers and the infrastructure to convert ideas into proof of concept. By supporting innovators at The Drivery FORVIA is connected to new technologies that will change the future. The concept is currently being expanded to further regions including China and Japan.

03

## Digital ways of working

Increase agility and collaboration to enhance customer and employee experiences

**800**  
members

**140+**  
mobility start-ups

**100**  
top mobility events hosted



07

## Expert-driven innovation

**Today's mobility challenges require collective thinking. At FORVIA, we believe in pooling knowledge and working collaboratively to ensure that we meet our customers' needs with innovative and sustainable solutions.**

FORVIA has built up an open innovation ecosystem that brings together our own scientific and technical experts with a range of partners across universities, think-tanks, start-ups and technology or industrial specialists.

This international network allows FORVIA to strengthen our areas of expertise, build on latest technology and science applications, acquire critical new competencies, and contribute to advances in technical and industrial domains.

In addition to the Group's own strategic R&D projects, FORVIA is also an active player in consortium projects involving industry, start-up

and academic collaboration – a good way to secure appropriate funding, bring together the required skills and share innovation risk. This includes four EU-funded programs exploring sustainable manufacturing, for example creating materials from CO<sub>2</sub> waste and circular approaches for automotive electronics.

Our network of tech and start-up scouts identifies promising partners with disruptive ideas in multiple areas like energy management, optics, artificial intelligence or materials science. By interconnecting ideas and expertise globally, and applying a structured innovation methodology, FORVIA can be more agile in bringing new and differentiating solutions to market.

# FORVIA's network of experts

- Tracking latest evolutions in the expertise domain
  - Transversal knowledge sharing
- Industry, start-up and academic coordination



## 08

# A valued partner for customers

**In bringing Faurecia and HELLA together, FORVIA has a diversified technology offer and expanded geographical reach. We are ideally positioned to meet the needs of our customers and shape future mobility.**

FORVIA's order book is the strongest indicator of customer satisfaction and trust. In 2022 the Group recorded €31 billion in order intake, while implementing greater selectivity in the choice of programs, aligned with the Group's POWER25 goals. Contracts include major seating programs with Mercedes-Benz electrified vans and with Volkswagen for the Porsche Cayenne, hydrogen storage systems with Hyvia for Renault light commercial vehicles, multiple interiors programs with Stellantis and over €5 billion in orders with Chinese automakers. The Group also secured contracts for innovations in Lighting and Electronics, including front phygital lighting shields for multiple electric vehicles.

FORVIA has a customer-centric culture focused on continuous improvement at all levels.

Beyond contract awards, customer confidence is reflected in recognition awards for global performance in areas from operational excellence, quality and innovation. In 2022 these included awards from BYD and Li Auto in China, Hyundai in Korea, Jaguar Land Rover in the US, and Nissan in Mexico.

For a global view of customer feedback across the entire value chain, Faurecia has a dedicated Five Star Customer Experience application. In 2022, this application had nearly 1,500 unique users and 2,030 reviews, giving an average rating of 4.6 stars out of 5.

# 2022 in review



FORVIA is in constant dialogue with customers, sharing strategy and technologies at dedicated events and global tradeshows. We showcased Faurecia and HELLA innovations through 16 demonstrators at the Consumer Electronics Show in January 2023 in a specially and sustainably designed booth that was highly appreciated by customers. New in 2022 was FORVIA's first Sustainability Day where we presented our 2045 net zero roadmap as well as MATERI'ACT, the new Group entity dedicated to sustainable materials.



A 2022 highlight and good example of close commercial cooperation between Faurecia and HELLA's electronics teams was a major award from Volkswagen in South America for in-vehicle entertainment displays and systems. Three million displays will be produced at the HELLA electronics plant in Indaiatuba, Brazil.

**1,000+**

programs

**80+**

automotive customers

**€31bn**

order intake for 2022

**43%**

electric vehicle

**61%**

premium / SUV



"Our customers look to FORVIA as an integrator and full service provider. Now we reinforce our position as a leading automotive technology supplier through our new solutions in electrification and energy management, safe and automated driving, and digital and sustainable cockpit experiences."

**Thorsten Muschal,**  
Executive Vice  
President, Sales  
& Program Management



## 09

# Operational excellence

**In an increasingly competitive market, agility, flexibility and profitability are key. FORVIA continues to transform its industrial activity to ensure the total safety of its teams in parallel with total customer satisfaction.**

Since 2017, the Group has embarked on a digital transformation program to strengthen economic, operational and environmental performance. The deployment of smart automation tools (robots and AGVs\*) and new data analysis and 3D simulation systems facilitate product assembly and handling, increase plant management agility and improve overall efficiency. Faurecia has recruited "Plant Digital Managers" to steer each site's digital roadmap. The Group is also committed to standardizing and specializing its plants to enable scalability to optimize investment towards increasing output per plant.

Operational excellence includes energy efficiency. In 2022, FORVIA accelerated its action plan to achieve carbon neutrality in operations by 2025, in particular through the signature of Power Purchase

Agreements increasing the use of renewable energies and the installation of sensors for more precise energy management. The Group is also taking steps to improve its environmental footprint: sorting and recycling waste, reusing production waste, raising employee awareness of good practices, etc.

FORVIA is committed to providing a safe working environment with an objective of zero accidents. Site policies are based on 7 Safety Fundamentals, which are simple rules designed to avoid accidents. They are a core element of the CARE program used by all sites to detect and eliminate safety risks, promote right behaviors, and ensure engagement of all employees. These rules are complemented by measures to improve workstation ergonomics. All employees of FORVIA are regularly trained in the 7 Safety Fundamentals, which are reiterated during CARE moments to ensure a very effective internal communication.

\* Automated Guided Vehicles.



## Toward a FORVIA Excellence System

The Faurecia Excellence System (FES) drives continuous improvement with a triple focus on customer satisfaction, sustainable competitiveness and the development of talent in a safe working environment. In 2023, it will be adapted and extended to HELLA's activities and will become the FORVIA Excellence System. Operational efficiencies and flawless program management underpin FORVIA's POWER25 enhanced profitability target.



## FORVIA Industrial Awards: Best Plant

The Industrial Awards is a new recognition program launched in 2022. Open to Faurecia plants, it recognizes performance in three areas: half-yearly operating results, Faurecia Excellence System control and digital deployment. The highest distinction, the FORVIA Best Plant award, is given to plants that score an A in each category. In 2022, the Tarazona Interiors plant in Spain proudly received this award.



## The model plant approach

A model plant operates with fully digitalized FES production system. This concept, implemented and tested at the São João da Madeira (Portugal) and Tarazona (Spain) sites, was rolled out to 40 Faurecia sites by 2022, with a target of 30 additional plants per year. Pilot plants have amortized their investments in less than a year and recorded gains in operating income.



## Energy efficiency campaigns

The Group aims to reduce its energy consumption by more than 30% in 2025 compared to 2021 (MWh/EM). In 2022, Faurecia launched a "We save Energy" communication campaign in all sites in 2022 in order to raise teams' awareness of environmental issues and encourage them to optimize consumption. This campaign has been extended to HELLA sites, strengthening its "Think. Act. Save!" energy optimization approach.



# 10

## Robust risk management

**The step change to FORVIA, with our more balanced, diversified offer, expanded reach and robust governance, strengthens our resilience in the face of a complex and evolving market environment.**

FORVIA's Risk Committee oversees the Enterprise Risk Management program, which is based on the ISO 31000 standard and a 3-line management model (operational, functional and internal audit). Since 2022, it has also been supported by a global network of correspondents across FORVIA's functions, Business Groups and regions. The Board of Directors and its Audit Committee continuously monitor this process.

The Group has identified 22 major operational and industrial, financial and legal risks that it could possibly

face. Each year these risks are reviewed by FORVIA stakeholders, integrated into a risk analysis matrix and approved by the Group's Risk Committee.

In order to monitor changes to these 22 risks as closely as possible, FORVIA has established over 120 key risk indicators. These enable the anticipation of any event that could impact the Group and, if necessary, adapt targeted action plans (e.g., the Safer Together procedure for Covid-19, business continuity plans in the event of energy shortages or supplier disruptions).

FORVIA classifies its risks in 3 categories (A, B and C) according to the degree of threat and opportunity. This classification is used to allocate risks to the right part of the organization that will provide the most appropriate response.

### Risk classification

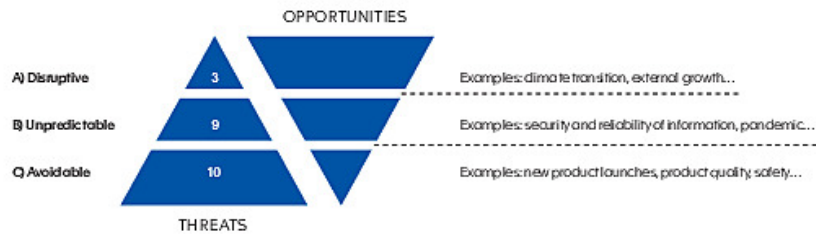

# Ethics and compliance: a top priority



FORVIA is committed to conduct business in a responsible way everywhere it operates, complying to the highest ethical standards. FORVIA is fostering a culture of integrity and promotes the respect of fundamental rights for all, the development of economic and social dialogue, the expansion of skills, and the observation of ethics and rules of conduct.

The Group's anti-corruption Code of Conduct, available in 12 languages, enshrines best practices concerning anti-competitive practices as well as policy on gifts and hospitality, donations and sponsorships, managing conflicts of interest, and the golden rules of competition law.

In addition, regular controls are carried out in functions exposed to corruption risks, and the Group's internal audit leads special yearly missions to assess anti-corruption and risks programs.

The Group communicates regularly on its ethics standards to ensure that all its business partners are committed to respecting them.



## Promoting a speak-up culture

Developing a speak-up culture is a key element of our zero tolerance for non-compliance.

Everybody within Faurecia is encouraged to raise concerns or report violations of applicable laws, internal policies and processes via the Speak Up line: [www.faurecia.ethicspoint.com](http://www.faurecia.ethicspoint.com).

All alerts are received only by the Group Chief Compliance Officer and Group General Counsel. They ensure, with the Regional Compliance officers, the anonymity of the whistleblower.





We pioneer  
technology  
**for mobility  
experiences  
that matter  
to people.**

**Behind and  
beyond future  
mobility**



# Electrification and energy management



**FORVIA** / 2022 Universal Registration Document  
faurecia

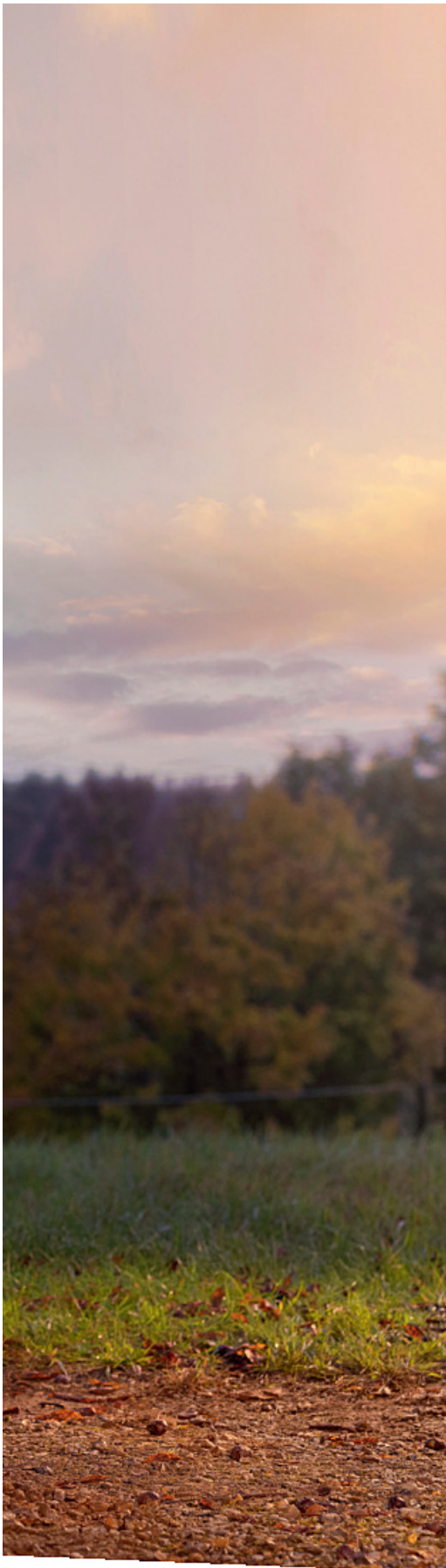

FORVIA develops the technologies that are helping our industry transition to ultra-low and zero-emissions mobility. Explore how we're improving the performance, range and experience of new energy vehicles, from powertrain electronics and energy and thermal management to hydrogen mobility solutions.

## Electrification and energy management

# A flexible partner for zero emissions mobility

Future mobility will be both electric and hydrogen powered. FORVIA is uniquely positioned to support automakers in their transition to zero emissions mobility with a comprehensive technology offer to suit every electrification strategy.

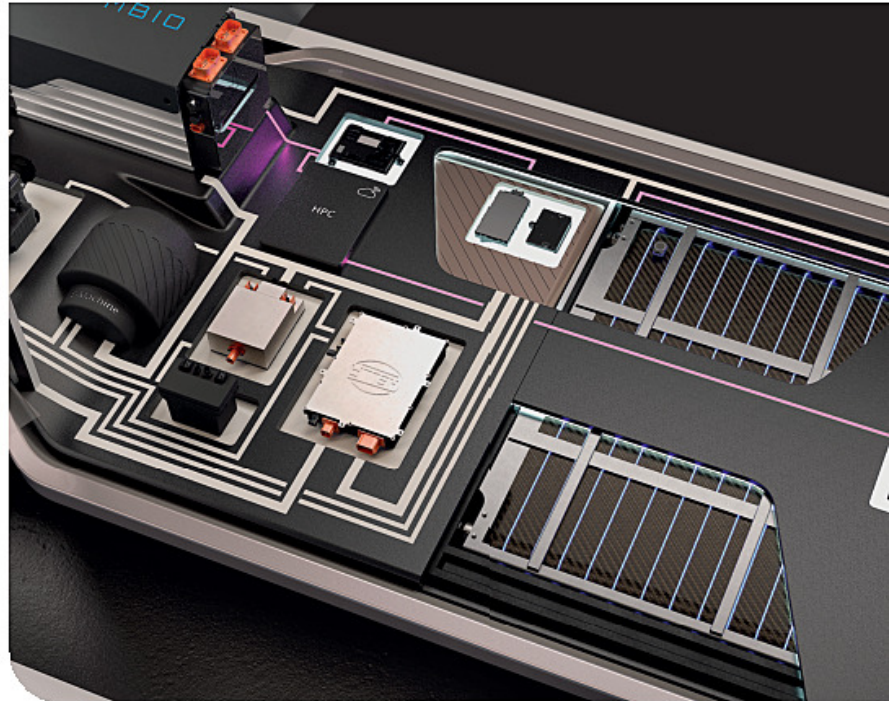

Automakers worldwide are implementing their roadmap to vehicle electrification. Given the needs of different use cases and pressures on battery materials, it's clear that a variety of new energy vehicles will be required.

FORVIA offers a flexible portfolio of electromobility solutions no matter what strategy makes the most sense for each automaker. Our technology portfolio combines HELLA's expertise in battery electric vehicles with Faurecia's leadership

in the entire hydrogen mobility value chain adapted to the different requirements across automotive, transportation, logistics and industry.

Together, we create market-leading systems that combine expertise in power electronics, energy management, thermal management and intelligent power distribution, with an optimal balance between efficiency, safety, durability and cost.

FORVIA can integrate its range of electromobility technologies

into the same electric vehicle skateboard platform to support battery, hydrogen-powered or even hybrid powertrain architectures. This technology blend showcases the scope of solutions we can offer, and delivers the best combination of range, charging times and charging convenience, as electric vehicle infrastructure is scaled up around the world.

HELLA brings to FORVIA a growing portfolio of technologies to optimize the performance, range and efficiency of electric vehicles. Solutions are all designed to reduce the size, complexity and cost of components, cutting down on weight and improving efficiency.

**For power conversion:**  
a high-density onboard charger offering faster charging cycles and smart vehicle-to-grid capabilities at 15% lower weight and 20% lower volume than conventional chargers.



**For battery management:**  
a modular and scalable high-voltage solution to manage the safe and reliable function of Lithium-Ion batteries in hybrid and electric vehicles.



**For thermal management:**  
a customizable solution to connect up to three cooling and heating cycles for the battery, power converters, electric motor and vehicle interior with significant material and energy savings.



**New service-oriented E/E architecture**

Drawing on its expertise in software and electronic hardware development and production across all domains as well as safety-relevant functions such as energy management, steering and braking, FORVIA is helping automakers reduce the complexity of electronic/electric architecture. Zonal modules support and relieve centralized high-performance computing by managing information within a

geographic zone. They integrate and reduce the number of discrete components and wiring, thus reducing weight and complexity.

We are one of the first Tier 1 suppliers to implement secure ethernet connectivity for real-time updating and upgradability and to provide the market's first integrated electronic fuse (eFuse) which ensures fail-operational power supply (up to ASIL D safety standards) for automated driving functions.

## Electrification and energy management

# Scaling up hydrogen mobility

A pioneer in fuel cell stacks and hydrogen storage solutions for mobility, distribution, transport, and stationary applications, Faurecia is at the heart of a range of projects and partnerships accelerating hydrogen mobility on a global scale.



## Best-in-class hydrogen storage solutions for mobility

Hyvia, a joint venture between Renault Group and Plug Power, selected Faurecia to provide hydrogen storage systems for its next generation of Renault Master H2-Tech vans. Leveraging on its strong experience as a tier 1 automotive supplier, Faurecia brings its expertise in gaseous hydrogen storage systems for light commercial vehicles, and in manufacturing high quality automotive parts for mass-production, to provide the best combination of payload, available space and autonomy. The serial production of the tanks and complete hydrogen storage systems will take place in our plant in Allenjoie, France. Faurecia's hydrogen storage systems have been on the road on both light and heavy-duty applications since 2021, for example with the Hyundai XCient truck.

## Containerized solutions for hydrogen transportation

The Zero Emission Valley project, backed by a consortium of public and private investors, intends to deploy 1,200 fuel cell vehicles and 20 hydrogen stations in the Auvergne-Rhône-Alpes region in France before the end of 2024. The goals of this project are to make this region a pioneer in hydrogen mobility and one of the first carbon-neutral territories in Europe, as well as to test profitable models for hydrogen mobility that can be replicated across the EU. To enable this project, Faurecia's ambition is to provide large, lightweight hydrogen storage containers that will allow reliable and safe transportation of hydrogen in the Zero Emission Valley.



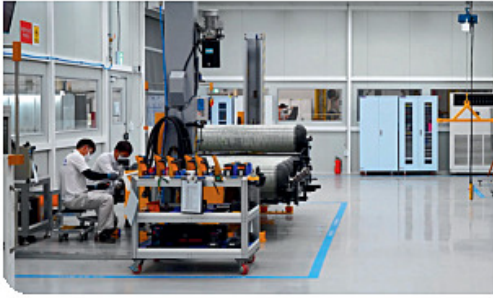

## Expanding our industrial footprint

In 2022, following the successful creation of an assembly line in Korea, Faurecia launched in Shanghai a new assembly line for complete hydrogen storage systems, enhancing its product offer for the Chinese market. In Europe, Faurecia will manufacture tanks and complete storage systems at its Allenjoie plant in France. Allenjoie, a model plant in terms of sustainability, is the second Faurecia site in Europe to receive the "BREEAM Excellent" certification for its environmental performance. The production of hydrogen tanks and storage systems in Allenjoie starts in 2023, with a ramp-up plan to reach a capacity of 100,000 tanks per year.



## Growing Europe's hydrogen ecosystem

The European Union and French government are investing massively in their hydrogen technology and industrial capability through €2.1 billion attributed to 10 key hydrogen projects of Common European Interest. Two projects within FORVIA Group have been selected. Faurecia's "History Next" project will receive €213 million to support two new generations of carbon fiber gaseous hydrogen tanks, as well as for liquid hydrogen storage. The project will include accelerating development of more sustainable tanks focusing on the use of low-carbon materials and recyclability. Symbio, a Faurecia and Michelin hydrogen company and leader in fuel cell technologies, has also received substantial EU and French funding to scale-up industrial production of fuel cell stacks at a gigafactory in France.



## Innovating for mobility

As one of the industry pioneers of hydrogen storage systems, Faurecia develops next-generation hydrogen storage solutions that allow automotive manufacturers to offer fuel cell electric vehicles with great autonomy. Our engineers are developing an innovative prismatic high-pressure tank that offers up to 50% more storage capacity and therefore greater autonomy compared to cylindrical tanks. A first preview of the concept was unveiled at the Consumer Electronics Show in January 2023. In parallel, since 2021, Faurecia has been partnering with French industrial gas supplier Air Liquide to develop onboard liquid hydrogen tanks for heavy-duty mobility. These will provide higher autonomy to long haul trucks and other vehicles operated for intensive uses.

## Electrification and energy management

# Rethinking next generation electric vehicles

Electrification is accelerating with multiple technology and architecture options. FORVIA is at the heart of research and innovation efforts to help automakers make the right strategic choice across powertrain, interior and electronics technologies.



## Battery research with Collège de France

Battery life is a key challenge for electric vehicles. But what actually happens inside an electrochemical cell when it's part of an energy system is less well understood. In a joint research project, FORVIA and Collège de France set out to explore how sensors could be used to measure temperatures within a battery cell to improve thermal management and durability. Using fiber optic techniques from medical science, researchers were able to 'see' and monitor temperature evolution in real-time in a system of interconnected cells similar to those in a conventional battery. Jean-Marie Tarascon, Chair in Solid Energy Chemistry at the Collège de France: "This pioneering research has led to three patents and shown the value of new diagnostic and testing approaches for industrial applications."

# 43%

of FORVIA's 2022 orders were for electric vehicle programs

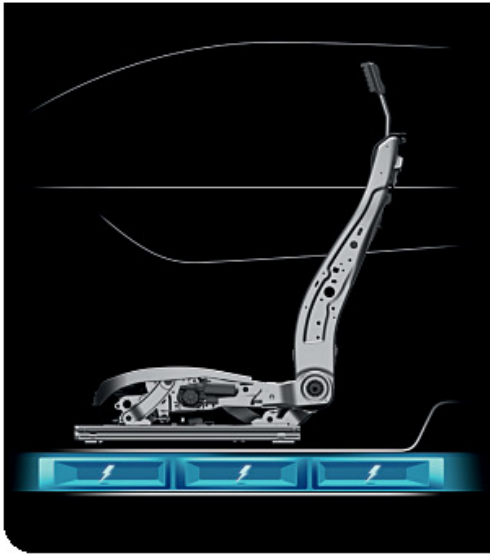

## Extending range and comfort through seating

Battery electric vehicles present new design opportunities: the size and integration of the battery pack and related energy systems define the available interior space. Building on our leadership in seating and seat structures, FORVIA has created the market's most compact and lightweight seat platform to improve battery storage configurations within electric vehicles. This seating concept is streamlined and sustainable: it includes structural parts made from green steel, new compact cushions and smart actuators connected to stepless tracks for a more natural adjustment motion. In addition to extending the C-SUV electric vehicle range by up to 40km, it creates a more comfortable experience for passengers in the rear through improved legroom. It's a good example of FORVIA's expertise in cockpit design and energy management for future electromobility.

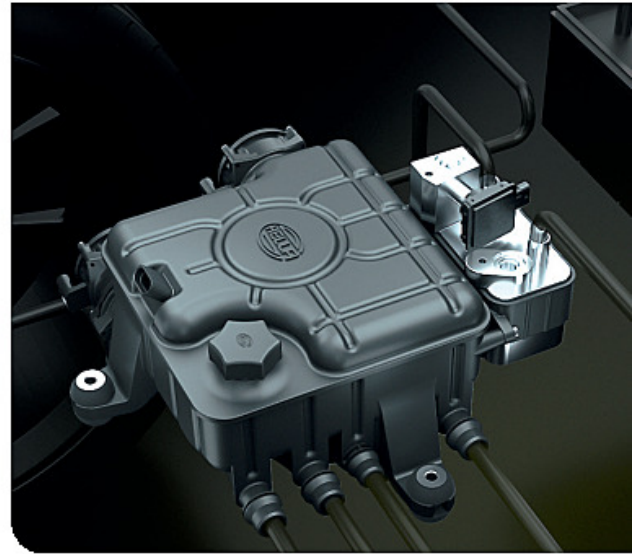

## Coolant Control Hub: efficient thermal management

Thermal management is key to safe electrification. The distribution, conversion and use of power creates heat that can reduce the life of components and cause safety risks when overheating. Conversely, too cold environment temperatures reduce the efficiency and lifetime of electronic components. Efficient thermal management improves the performance of electric vehicles in terms of battery life, powertrain efficiency and passenger comfort. FORVIA's Coolant Control Hub combines all cooling loops needed to cool the battery and power conversion devices, the electric motor and the vehicle interior while reducing the number of components by up to 50%. Through a modular design adapted to different electric vehicle systems, we reduce the complexity, cost of materials and logistics, as well as efficiently recover energy to provide on-demand heating and cooling to improve the range of electric cars.

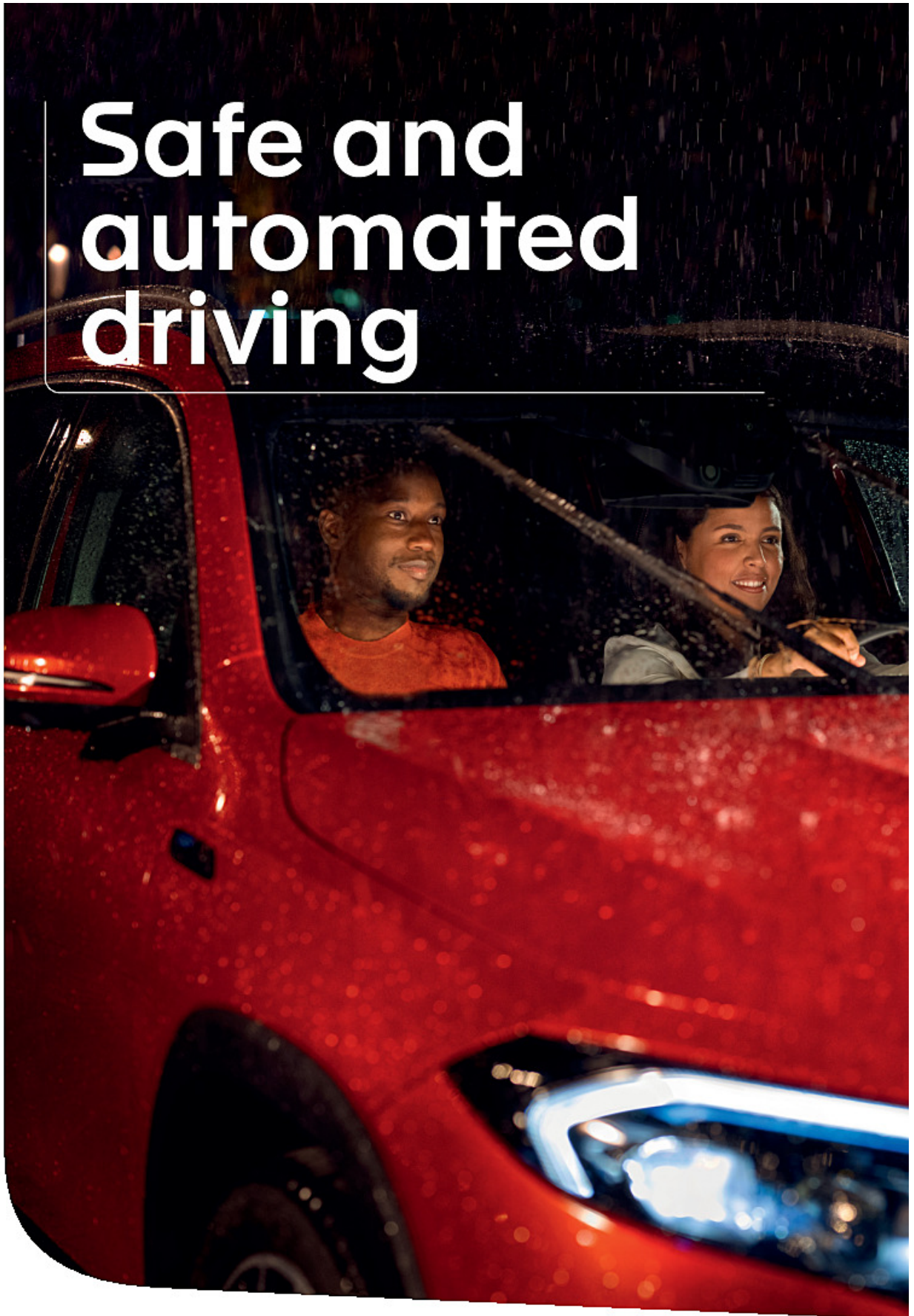

# Safe and automated driving



FORVIA's technologies inside and outside the vehicle play a vital role in a safer driving environment. See how we're building public trust in future automated and autonomous mobility modes through safety-critical solutions – from best-in-class sensors to intelligent lighting and innovative by-wire vehicle controls.

## Safe and automated driving

# Vision systems for safer roads

### Surround view

We bring a dynamic 360° visualization of the surrounding environment through fusing data from an intelligent system of cameras and ultrasonic sensors positioned around the vehicle. This short to mid-range vision system supports both automated driving and autonomous parking with a 3-D view from a range of different angles. FORVIA has been producing such systems for more than 15 years.



### Interior monitoring

We offer different technologies to monitor the driver and other occupants, giving the flexibility to combine safety, comfort and well-being use cases cost-effectively in one solution. This draws on FORVIA's expertise in integrating compact cameras and sensors into the best locations of the cabin interior.

Seeing, understanding and reacting to potential risks in the driving environment is critical to keeping road users safe. FORVIA provides the vision systems outside and inside the vehicle that ensure that drivers and automated driving functions are making the right decisions. Combining sensors through intelligent software, these detect and inform of any variability that may impact road safety.

**eMirror**

FORVIA's eMirror replaces exterior wing and rearview mirrors with sensors that bring the surrounding view to the driving display. Our system incorporates advanced image processing to enhance visibility in challenging light or weather conditions. Starting in 2023, FORVIA will be among the first to equip vehicles in China.

**Radar**

Our latest generation 77GHz corner radar uses innovative antenna technology to provide an increased field of view, extended distance recognition and greater precision in close proximity. HELLA has more than 20 years' experience in radar development with over 50 million\* radar sensors produced.

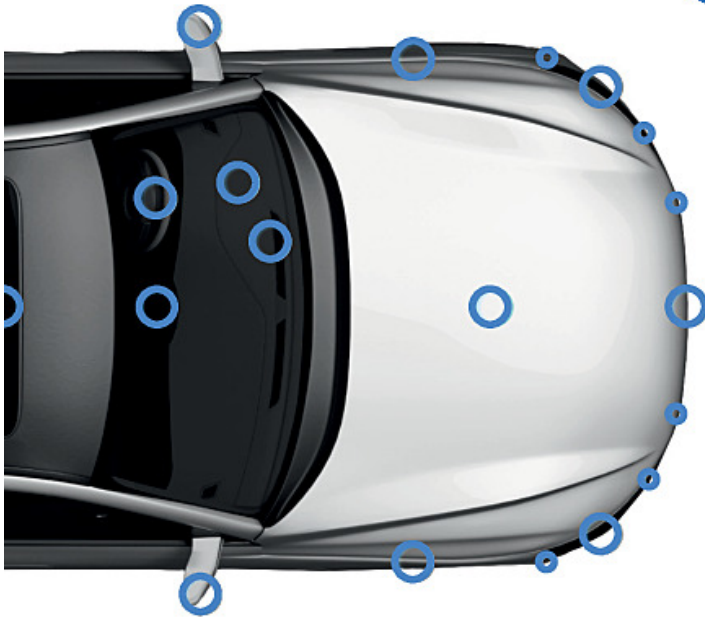

**Environment sensors**

Our multi-function rain/light sensor detects a range of humidity, light and temperature variables, while the SHAKE road condition sensor monitors road wetness and conditions. This data is used to activate driver alerts or adapt driving dynamics in real-time to the actual state of the road.

To achieve a 360° view of a constantly evolving context, you need the right combination of distance and near field sensing around a vehicle. FORVIA brings a wide portfolio of proven sensors, from radars to cameras, software for detection and image enhancement software, coupled with sensor fusion algorithms to provide a seamless environment perception. Our solutions enable the vehicle to

continuously and precisely detect stationary objects or road boundaries and dynamically track moving elements such as pedestrians, bicycles or cars, supporting autonomous driving. Regulations are driving the introduction of new safety features such as driver monitoring and child presence detection. Our interior monitoring systems – based on

camera, radar or ultrawide band technologies – aim to protect and safeguard everyone onboard and around the vehicle. This includes protecting drivers against drowsiness or distraction and detecting movement and breathing inside a stationary or locked vehicle in case of a child or pet left behind.

\* Including Joint Venture Korea business with HMM C.

## Safe and automated driving

# Intelligent lighting for better interactions

Lighting is essential for seeing and being seen. FORVIA provides dynamic and customizable solutions that address three central preoccupations for automakers: safety, design and sustainability.



## Award-winning brilliance

How headlamps illuminate the road surface varies depending on the driving context. Our Solid State Lighting | High Definition (SSL|HD) digital headlamp system is the world's first high-resolution headlamp that creates light with individual software-controlled LEDs. With up to 25,000 LEDs on each chip, it provides better illumination on the road while improving safety with smart functionalities such as projecting safe distances or lane markings onto the road, safety zones for cyclists or pedestrians, and vehicle widths in tight spaces. SSL|HD is lighter and up to 75% smaller than previous generation modules, creating new possibilities for integrating the headlamp into vehicle architecture while reducing fuel consumption. This solution gained an Innovation Award 2023 at the Consumer Electronics Show in Las Vegas.

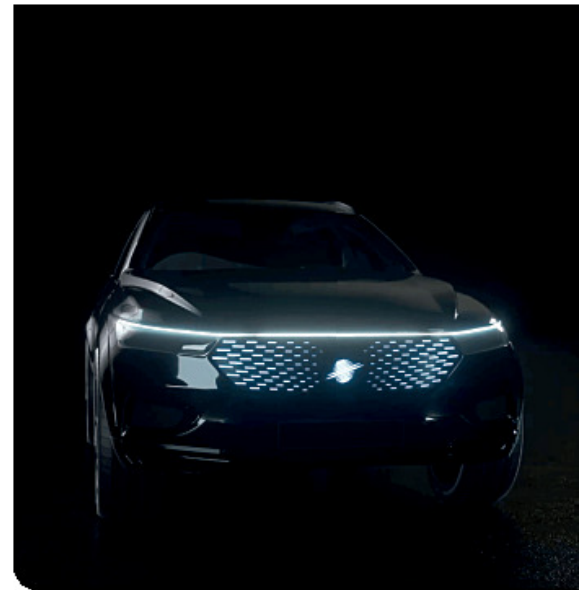

## Radiant new possibilities

Electric vehicles do not need traditional radiator grilles, which opens up entirely new ways to design the front of cars. HELLA created its front phygital shield as a highly integrated module that offers automakers the design freedom to showcase styling elements, provide advanced functionality for automated driving use cases and upgrade dynamic lighting via software updates. Integrating multiple LED segments for dynamic surface illumination and different individual animations, our solution also includes heating elements to protect the reliability of front sensors and a self-healing function to repair minor damage using heat from sunlight. Since pioneering this technology, HELLA has received over €1 billion in orders.



## Multifunctional rear lighting

What if vehicle lighting could improve visibility, enhance design and interactions between the car and road users? Through our Digital FlatLight, an innovative multicolor and multifunctional rear lamp system, HELLA creates luminous surfaces that communicate through signature lighting. Made of lightweight, multicolor FlatLight elements in combination with a smart glass layer, these systems reduce weight and use up to 80% less energy than traditional taillights, increasing the overall sustainability of vehicles. Automakers can use FlatLight to integrate taillights, stop lights and turn signals into one module, highlight design and branding signatures, or display warnings to other road users of traffic jams or safety hazards. And FlatLight functionality can be upgraded throughout a vehicle's life via software updates.



## Lighting up the interior

Drawing on the lighting, electronics and cockpit interiors expertise across the Group, FORVIA offers a range of adaptive cabin lighting to transform the onboard experience for drivers and passengers. Interior lighting can be used to create more immersive and personalized zones that enhance comfort, well-being, mood or alertness during the day or night. Automakers can embed dynamic surface lighting and decorative backlighting solutions to style the vehicle cabin and create ambient aesthetics. Combining the necessary lighting and electronics components in small and lightweight packaging, lighting solutions are designed to be cost-effective, scalable and customized in an unlimited number of colors, and deliver up to 70% weight savings per vehicle.

## Safe and automated driving

# By-wire control: the future of steering and braking



Electric mobility and autonomous driving are two trends powering the uptake of by-wire solutions that can replace mechanical systems. FORVIA is supporting the design of safe, automated and customizable driving experiences with innovative by-wire braking and steering technologies.

By-wire systems replace mechanical components and connections with advanced electrically managed controls, supporting automated driving features as well as customized steering and braking feel. Through HELLA's 20+ years expertise in electronics and mechatronics, FORVIA contributes the central components: sensors and control electronics.

### Steer-by-wire

Automated driving requires the highest security levels to ensure the safe steering of a car, especially when control passes from human to vehicle. Two key elements for steer-by-wire control are the road wheel and hand wheel actuators. Together these provide steering angle range, steering assistance and active power feedback, adapted to the driving context and giving a smooth and customizable steering experience. This kind of demand-driven operation increases energy efficiency and electric vehicle autonomy. Fully by-wire steering systems can also bring new design options for the interior by removing the linkage for a bulky steering column. FORVIA can integrate the steering wheel hub into the instrument panel structure, simplifying design, assembly and airbag performance for improved safety. Our by-wire steering technologies provide fail-operational electronics and support up to level 4 autonomous driving.

Eliminating the steering column creates a roomier space – ideal for future autonomous experiences when the driver is relaxing instead of driving.



### Brake-by-wire

Brake-by-wire pedal sensors simulate the feel and behavior of a conventional brake pedal but transmit braking signals electronically instead of through mechanical and hydraulic components. HELLA has designed its all-electric brake pedal system to be lighter, sleeker and customizable to different driving scenarios to enhance safety and comfort for the driver. A compact design also makes it more sustainable; it's 20% lighter than traditional braking pedals, helping to increase

FORVIA brings sleeker design and customized pedal interaction thanks to its brake-by-wire technology.

the range of electric cars as well as reduce assembly and installation costs.

For automated driving, it is critical that the car can still operate safely even in case of technology failure. Our braking and steering by-wire systems are designed with a redundant fail-operational architecture based on different technology that takes over in the unlikely event of a failure.

By-wire systems also bring significant design and engineering flexibility. Adding electronics expertise to our extensive range of solutions for the entire cockpit interior, FORVIA is uniquely placed to support automakers shape the next generation of safe and automated driving experiences.



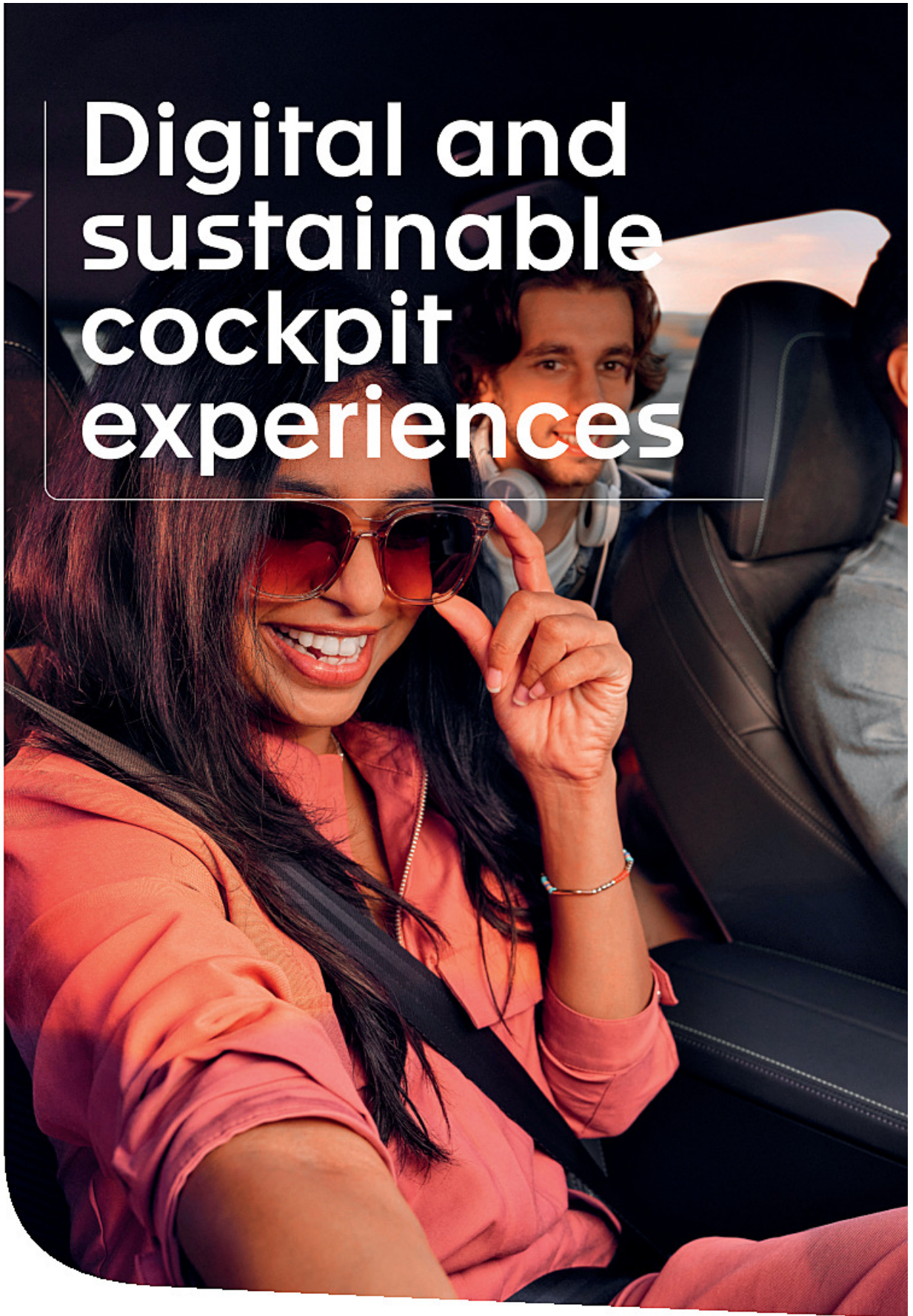

# Digital and sustainable cockpit experiences



At FORVIA, we bring sustainability and innovation together to customize solutions that are connected, intuitive and versatile and that benefit customers, consumers and the planet. Explore how we frame everything through the lens of sustainability, anticipating user expectations for extended vehicle life and advanced experiences.

## Digital and sustainable cockpit experiences

# Connected services: safe, affordable, sustainable

Digitalization of the onboard experience is booming in all types of vehicles. FORVIA brings its electronics and software know-how to enhance the quality, reliability and relevance of cockpit connected services.

The vehicle display is a key enabler for safe, connected and immersive experiences, providing the visual interface for applications, from instrument cluster information and driving assistance to onboard entertainment. With expertise across the entire cockpit interior, FORVIA is developing solutions for many of today's key automotive design challenges, notably

- how to integrate high-definition visual displays but avoid cognitive overload
- achieving best quality visual performance with energy efficient components
- ensuring a more sustainable approach through keeping vehicles and onboard features up-to-date for longer.



### A customized and connected offer

FORVIA is a leading cockpit services provider, providing a range of connected and upgradable solutions. The Faurecia Aptuide apps market offers 250+ automotive ready applications that can be customized into vehicle infotainment systems. By 2025, an estimated 17 million vehicles from seven different automakers will feature this onboard. FORVIA is also an aggregator of news, gaming and other new software-based solutions such as secure

**Faurecia Aptuide:**  
250+ automotive-ready applications.

payment for pay-as-you-go services, cabin lighting enhancement or smart dimming to enhance the quality of display content. Bringing new content and services online faster helps to extend vehicle life by keeping infotainment systems up-to-date longer as well as bringing opportunities for new service monetization.

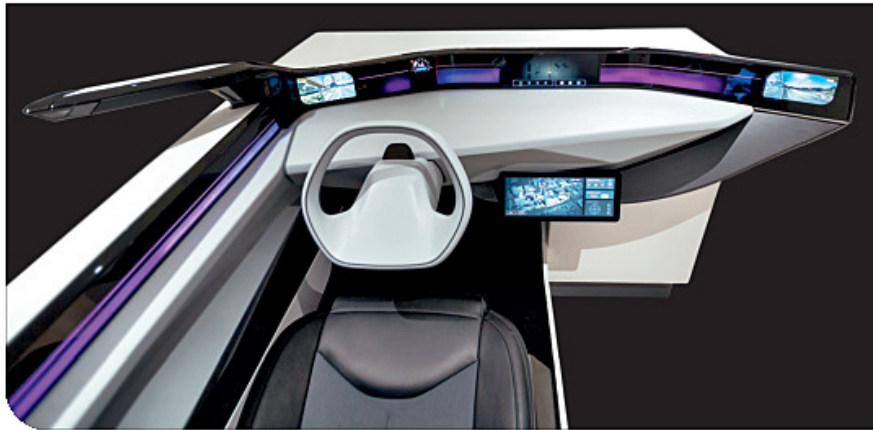

FORVIA's immersive vehicle display supports new safety use cases.

**Displays that drive greater safety awareness**

FORVIA hardware, software and integration expertise comes together into solutions for new safety use cases. One example is our immersive vehicle

display: it provides a more dynamic viewing experience the entire width of the vehicle through a seamless transition between high-definition LCD screens and LED panels. Dynamic lighting across this display can draw driver

attention to important safety information. Another safety feature is reactive dimming that automatically adjusts screen brightness to reduce distraction or highlight what a driver needs to see. FORVIA can bring added-value through

a cross-product approach that links multiple onboard systems: displays, gaze-tracking technology, driver monitoring camera, exterior vision systems and image processing algorithms.

Advanced image processing improves readability and reduces power consumption.

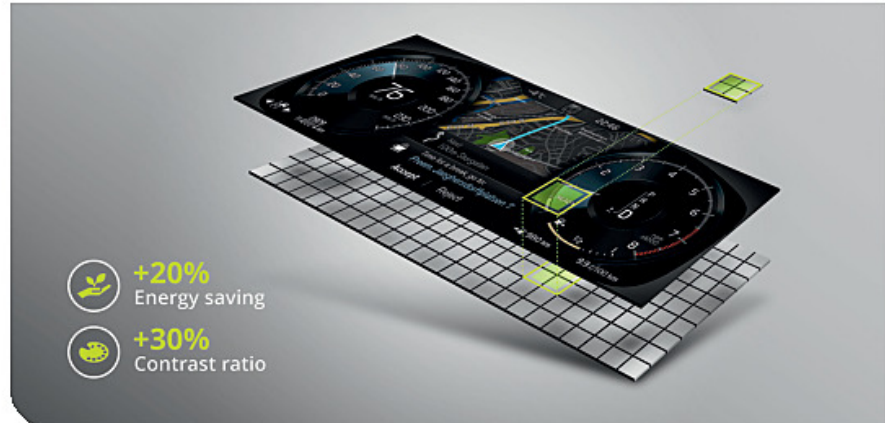

**Sustainable thinking for energy-efficient solutions**

Consumers expect the same exceptional visual performance from vehicle displays as from their smartphones, tablets or TVs. However, the

driving environment has many safety relevant considerations and is often exposed to very bright or dark light conditions. FORVIA has developed advanced image processing to improve screen clarity, readability

and power consumption on any type of display hardware. This approach brings a 30% better contrast ratio, with 20% energy saving compared to state-of-the-art local dimming algorithms. The solution provides automatic image

processing depending on the ambient light environment for optimal visibility and can be customized to the perceived quality, technology and cost requirements of individual automakers.

## Digital and sustainable cockpit experiences

# Modular and circular thinking by design

Future electric vehicles will have a longer life on the road. FORVIA is developing the solutions to make them more sustainable, versatile, upgradable and recyclable.

FORVIA is leading the way in a more sustainable and circular approach to key technologies for the automotive industry, inspired by three principles: use less, use better, use longer.

We rethink our products to reduce the carbon footprint of a vehicle maximizing its use and value. This involves eco-designing components to be easier to renew, replace or upgrade when they wear out, age or become out of date. By approaching product design with a circularity mindset, we're able to extend the lifecycle of our products and the vehicles they equip. Equally, our products are now simpler to recycle when they do reach the end of their lives, allowing their materials to find a second or third life.



## Modular seating

Seating is one of the vehicle's most complex cockpit elements. FORVIA is transforming this with a new modular seating approach for maximum flexibility, upgradability and sustainability. It reduces the number of components used from around 120 to 10 modules that can be assembled in a wide variety of configurations. Fewer parts means less complexity, less cost and less waste. Crucially, it also means seats can be repaired and upgraded throughout the vehicle's lifecycle. Modules are made from biosourced, recyclable and recycled materials including green steel to reduce carbon footprint.

They are designed to be easier to assemble and disassemble, so as to facilitate recycling at scale. They are produced in regional centers to allow car seats to be assembled as close as possible to the customer's site.

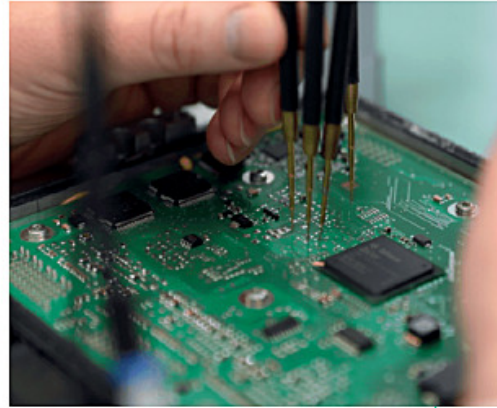

## Repair and reuse electronics

FORVIA is active in the aftermarket through its Lifecycle Solutions business group. Services include repair and remanufacturing of vehicle parts, a portfolio of 35,000+ different spare parts for wholesalers, and diagnostic equipment and tools to enable car mechanics to extend the life of vehicles and get them back on the road quickly. HELLA Tech World – an online platform for independent workshops – now integrates Faurecia's electronic repairs service across Europe for multiple products and brands from radios to navigation systems and complex electronic systems. Repairing and reinstalling components helps to significantly reduce CO<sub>2</sub> footprint, avoid waste and extend lifetime product use.

## Reconfiguring interiors

We've applied a similar approach to interiors components, designing with modularity front-of-mind to make it easier to reconfigure instrument panels, door panels and center consoles for better vehicle lifecycle management and customization. This brings three key advantages for automakers and consumers. Firstly, a common architecture to facilitate OEM car platforms management through modular design, such as a standard instrument panel structure. Next, the flexibility to customize or upgrade onboard features, like enhanced HMI controls or personalized lighting within FORVIA smart surfaces. Last but not least is a circular approach to refurbish or renew the appearance of materials or surfaces and ensure that parts that have been replaced can be recycled and materials reused.

## Digital and sustainable cockpit experiences

# Sustainable material innovation

To be CO<sub>2</sub>-neutral in our products, we have to radically rethink them – starting with what they're made of. FORVIA is taking the lead and accelerating its sustainable materials innovation.

As the first automotive company with a net zero target approved by the Science Based Targets Initiative, FORVIA has taken decisive action to ensure access to critical feedstock and the ability to scale-up development of new sustainable materials. November 2022 saw the creation of MATERI'ACT, a new Group entity bringing together more than 10 years' experience in the development of biosourced materials for lightweight products with a reduced CO<sub>2</sub> footprint. MATERI'ACT will further develop and manufacture unique cutting-edge materials with up to 85% CO<sub>2</sub> reduction versus current materials and no impact on water, biodiversity, circular economy and critical materials, in alignment with EU green taxonomy. This will strongly contribute to FORVIA's planet care

MATERI'ACT 

€2bn

sales by 2030

400

engineers by 2025

and CO<sub>2</sub> neutrality goals and more broadly support automakers in their drive to create more sustainable vehicles.

MATERI'ACT specializes in biobased and recycled compounds for interiors, seats and lighting; biobased foils as alternative leathers for seats and interiors; low-CO<sub>2</sub> carbon fibers for hydrogen tanks; and green steel for seat frames. It will operate from a dedicated R&D center with a pilot workshop set to open in 2023 in Lyon, France.



Compounds



Foils



Carbon fibers



Green steel

## A long history in sustainable materials

Materials innovation is in our DNA. Back in 2011, Faurecia was the first automotive supplier to introduce a biocomposite range made using natural hemp fibers. Today, we equip some 14 million vehicles with NAFiLean products, contributing to a reduction of more than 30,000 tons of CO<sub>2</sub> emissions in the production phase, including CO<sub>2</sub> capture during natural fiber growth, and an additional reduction of 72,000 tons in the car usage phase thanks to lighter weight.

Our latest generation – NAFiLean-R – has won several innovation awards in 2022 as a high performance and sustainable material. It's a fully recyclable composite made from low-emission natural fibers combined with post-consumer recycled feedstock. In addition to being up to 25% lighter, its CO<sub>2</sub> footprint is up to 87% lower than equivalent market references.



## Boosting recycled content use

Moving away from virgin plastics to the use of recycled plastics is core to our strategy. In May 2022, FORVIA signed a major partnership with Veolia to develop compounds made from post-used plastics. By combining our respective expertise in recycling and vehicle interiors, we will significantly boost the use of recycled plastics. By 2025 FORVIA aims to achieve an average of 30% of recycled content in our vehicle interiors, rising to 80% by 2030. We also showcased Inicycled, our new sustainable compound made from 50% recycled content, at the Consumer Electronics Show in January 2023.

## Ecorium

Non-animal leather is a great example of how FORVIA is translating its sustainability ambition into innovative materials with a significantly reduced CO<sub>2</sub> footprint. Ecorium offers a more environmentally friendly product incorporating recycled PET material and hemp with a great premium quality and aesthetic appeal.

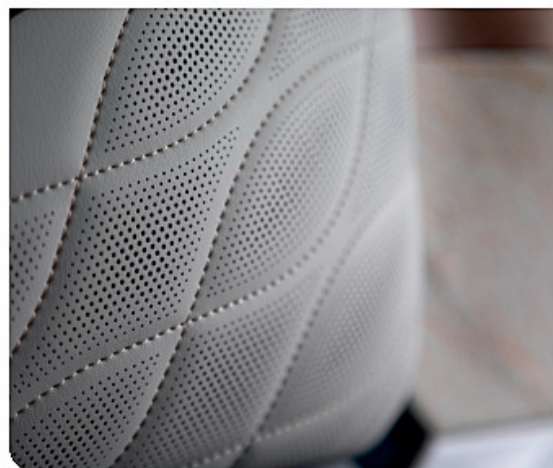

Governance and performance

# An effective governance

FORVIA's governance structure includes complementary governance bodies at Faurecia and HELLA with efficient decision-making processes at all levels of the Group.

The highest standards of independence, transparency, openness, inclusiveness and responsibility guide Faurecia's and HELLA's governance and ensure that the companies deliver on their joint strategy.

This governance model will allow Faurecia and HELLA to work efficiently together and progress in the best interests of both companies.

## One FORVIA, two listed companies

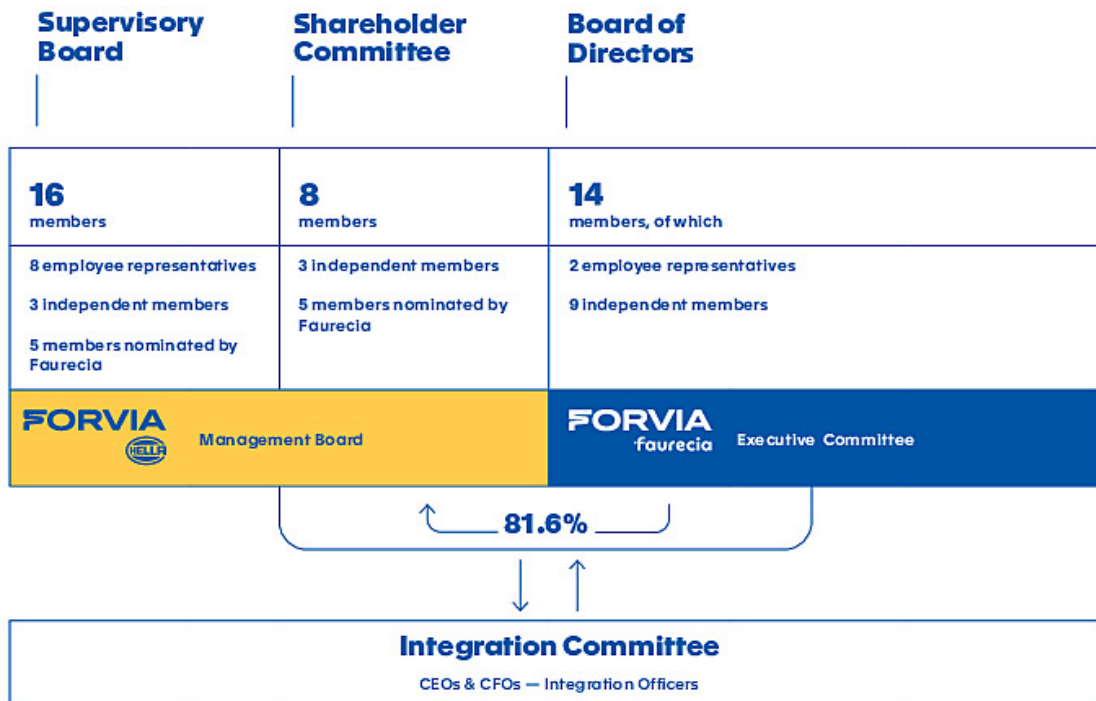

## Faurecia: an active and independent Board of Directors

As at January 1, 2023

The Board of Directors oversees Faurecia's business, financial and economic strategies, and implementation. Meeting at least four times a year, Faurecia's Board consists of 14 members, two of whom represent employees.

Three permanent Committees are tasked with preparing discussions on specific topics:

- the Audit Committee,
- the Governance, Nominations and Sustainability Committee,
- and the Compensation Committee.

They make proposals recommendations, and give advice to the Board of Directors in their respective fields of expertise.

### Evolution in 2022

Following the acquisition of HELLA, Faurecia holds a controlling interest of 81.6% of HELLA shares. As part of the transaction, the Hueck and Roepke family has become Faurecia's largest shareholder, with a circa 9% shareholding.

During the 2022 Faurecia shareholders meeting, the appointment of Dr. Jürgen Behrend to Faurecia's Board of Directors as a representative of the Hueck and Roepke family was ratified, underlining the family pool's strong commitment to the combined Group's strategy and outlook.

- Independent
- Governance, Nominations and Sustainability Committee
- Compensation Committee
- Audit Committee



**Michel de ROSEN**  
Chairman of the Board ● ●  
End of mandate – 2024 AGM



**Patrick KOLLER**  
Chief Executive Officer  
End of mandate – 2025 AGM



**Dr. Jürgen BEHREND**  
Managing general partner of Hueck Industrie Holding KG  
End of mandate – 2026 AGM



**Daniel BERNARDINO**  
Faurecia employee ●  
End of mandate – 31/10/25



**Judy CURRAN**  
Head of Automotive Strategy of ANSYS ●  
End of mandate – 2024 AGM



**Odile DESFORGES**  
Board member ● ●  
End of mandate – 2024 AGM



**Penelope HERSCHER**  
Board member ● ● ●  
End of mandate – 2025 AGM



**Valérie LANDON**  
CEO France and Belgium, Credit Suisse ● ● ●  
End of mandate – 2025 AGM



**Jean-Bernard LÉVY**  
Board member ● ● ●  
End of mandate – 2024 AGM



**Yan MEI**  
Senior Partner, Chair of China – Brunswick Group ●  
End of mandate – 2023 AGM



**Denis MERCIER**  
Deputy Chief Executive Officer of Fives Group ● ●  
End of mandate – 2023 AGM



**Dr. Peter MERTENS**  
Board member ● ● ●  
End of mandate – 2023 AGM



**Robert PEUGEOT**  
Permanent representative of Peugeot 1810, Chairman of the Board, Peugeot Invest ● ●  
End of mandate – 2025 AGM



**Emmanuel PIOCHE**  
Faurecia employee ●  
End of mandate – 31/10/25

## A strong, international and focused management

Members of Faurecia and HELLA's management hail from a wide range of backgrounds and contribute diverse and complementary skills.

Faurecia's executive functions are performed by an Executive Committee that meets at least once a month to review the Group's results and discuss operations and strategy.

Operating under the responsibility of the Chief Executive Officer (CEO), the Faurecia Executive Committee is composed of the CEO and 12 Executive Vice Presidents from the Group's international Business Groups and functional roles. Dr. Christopher Mokwa and Dr. Frank Huber come from HELLA.



### Executive Committee

As at January 1, 2023



**Patrick KOLLER**  
Chief Executive  
Officer



**Victoria CHANIAL**  
Executive Vice  
President, Group  
Communications



**Nolwenn DELAUNAY**  
Executive Vice  
President, Group  
General Counsel &  
Board Secretary



**Olivier DURAND**  
Executive Vice  
President, Group  
Chief Financial  
Officer



**Nik ENDRUD**  
Executive Vice  
President, Americas



**Dr. Frank HUBER**  
Executive Vice  
President, Seating



**Olivier LEFEBVRE**  
Executive Vice  
President, Clean  
Mobility



**Jean-Paul MICHEL**  
Executive Vice  
President, Interiors



**Dr. Christopher MOKWA**  
Executive Vice  
President, Strategy &  
Digital Transformation



**Thorsten MUSCHAL**  
Executive Vice  
President, Sales  
& Program  
Management



**Christophe SCHMITT**  
Executive Vice  
President, Group  
Chief Operations  
Officer



**Jean-Pierre SOUNILLAC**  
Executive Vice  
President, Group  
Human Resources



**François TARDIF**  
Executive Vice  
President, Asia &  
Clarion Electronics



## Management Board

As at January 1, 2023



**Michel FAVRE**  
President and  
CEO, Purchasing,  
Quality, Legal and  
Compliance



**Yves ANDRES**  
Lighting



**Dr. Lea CORZILIUS\***  
Human Resources  
and Lifecycle  
Solutions

The HELLA Management Board oversees the strategic and operational management of the HELLA Group. Michel Favre and Yves Andres are former members of Faurecia's Executive Committee.

\*Björn Twiehaus and Dr. Lea Corzilius will leave their respective positions on March 31, 2023, and April 30, 2023.



**Bernard SCHÄFERBARTHOLD**  
Finance, Controlling,  
Information  
Technology and  
Process Management



**Björn TWIEHAUS\***  
Electronics

## HELLA's Shareholder Committee and Supervisory Board

The Shareholder Committee, which consists of five members nominated by the majority shareholder Faurecia (Executive Committee members, Faurecia) and three independent members, is the decisive controlling body of HELLA. It supervises and advises the Management Board, determines which business transactions require its consent and decides on measures of the Management Board requiring approval.

The HELLA Supervisory Board is composed of 18 members, five of whom are nominated by Faurecia. Together with the Shareholder Committee, it advises and supervises the Management Board.

## Governance and performance

# FORVIA value creation model

## FORVIA resources



### PEOPLE

- **157,000** employees
- **150** nationalities in **43** countries
- **5** FORVIA University campuses\*
- **94,650** employees connected to the e-learning platform, 39% of whom are operators\*



### BUSINESS

- **€2,079m** gross R&D expenditure
- **Global** innovation ecosystem
- **15,000** R&D engineers
- **14,314** patent portfolio



### PLANET

- **130 hectares** of solar panels on 150 sites for green power generation
- **Creation of MATERI'ACT** to scale up sustainable material innovation
- **88%** of sites certified ISO 14001\*
- **21.5%** of sales aligned with green taxonomy

OPERATIONS EXCELLENCE

## Strategy & operational model

**FORVIA**  
Inspiring mobility

We pioneer technology

ooo

### OUR THREE STRATEGIC PILLARS

- Electrification and energy management
- Safe and automated driving
- Digital and sustainable cockpit experiences

○ **ENVIRONMENTAL, SOCIAL AND GOVERNANCE AS A BUSINESS DRIVER**



\* Faurecia data. The consolidation of FORVIA Group data is ongoing.  
\*\* Sites with at least 2 years of activities.

## OUR SIX BUSINESS GROUPS

○ Faurecia ○ HELIX

- Seating
- Interiors
- Clean mobility
- Electronics
- Lighting
- Lifecycle solutions

ooo  
for mobility experiences that matter to people.

- **POWER25: NEW MEDIUM-TERM PLAN FOR PROFITABLE GROWTH**

## Value created in 2022



### PEOPLE

- 27.3% of managers and skilled professionals are women
- 23%\* of the Top 300 leaders are women
- 22.9 hours\* of training per employee



### BUSINESS

- 1,502 patent filings in 2022
- 93% of our supplier panel screened for corporate social responsibility by EcoVadis\*
- Customer satisfaction: 4.6 stars out of 5\*



### PLANET

- **CO<sub>2</sub> intensity:** 33 tons of CO<sub>2</sub>,eq / € million sales
- **Energy intensity:** 101 MWh scope 1 & 2 / € million sales
- **Waste intensity:** 9.15 tons waste / € million sales

### 2022 REVENUES

**€25,458M**

### EMPLOYEES' SALARIES & SOCIAL CHARGES

**€5,487M** 21.6%

### SHAREHOLDERS' DIVIDENDS

**€55M** 0.2%

### BANKS FINANCE COSTS

**€334M** 1.3%

### STATES/COMMUNITIES TAXES

**€252M** 1.0%

### SUPPLIERS PURCHASES & OTHER EXTERNAL COSTS

**€18,210M** 75.5%

**Ability to finance future growth**

### INVESTMENTS IN FIXED ASSETS

**€1,177M** 4.6%

### GROSS R&D EXPENDITURE

**€2,079M** 8.2%

### INVESTMENTS IN ACQUISITIONS

**€6,359M** 25.0%

## Governance and performance

# 2022 financial performance



2022 was a particularly important year for us as we integrated HELLA to create FORVIA, the world's 7<sup>th</sup> largest automotive supplier. This has been a historic step for the Group, even if it has taken place in a difficult macroeconomic environment, particularly from February onwards with the outbreak of war in Ukraine.

2022 has continued to be impacted by the shortage of semiconductors and supply chain issues, but also by additional challenges: high inflation, energy risks and increased interest rates.

Despite this context, FORVIA sales rose sharply to more than €25 billion, including the consolidation of HELLA from 1 February 2022 as well as passing through some of the impact of inflation costs to customers. Operating margin was resilient at 4.4% of sales, with a marked improvement of 5% of sales in the second half of the year and a better-than-expected cash flow of €471 million across the full year.

In November, FORVIA presented its POWER25 medium-term plan to drive profitable growth, enhance cash generation and accelerate Group deleveraging. This debt reduction has been a priority since the payment at the end of January of the majority stake in HELLA. In addition to increasing cash flow generation, contemplated disposal transactions announced to date fulfill our divestment program of €1 billion in non-strategic assets by end of 2023. Our POWER25 plan is also well on track: in 2022, we decreased the Group's net debt/adjusted EBITDA ratio from 3.1 to 2.6, with a target of 1.5 by end of 2025.

**OLIVIER DURAND**  
Executive Vice President  
Group Chief Financial Officer

## Worldwide automotive production

**77.2 million**  
vehicles

**82.4 million**  
vehicles

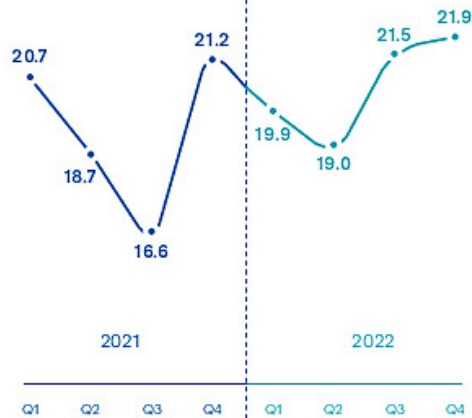

**25,458**

**15,618**

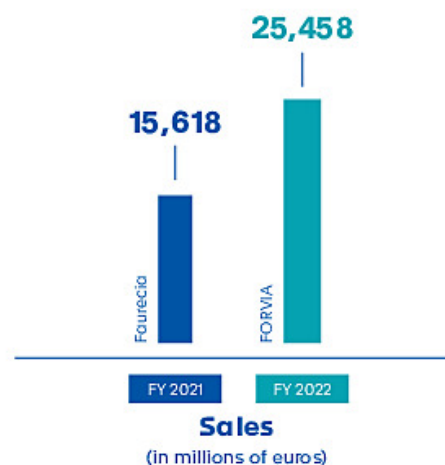

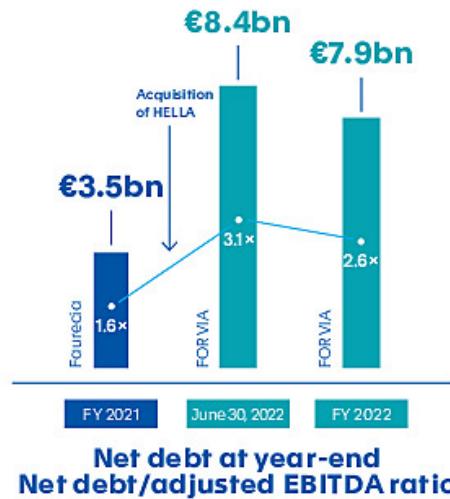
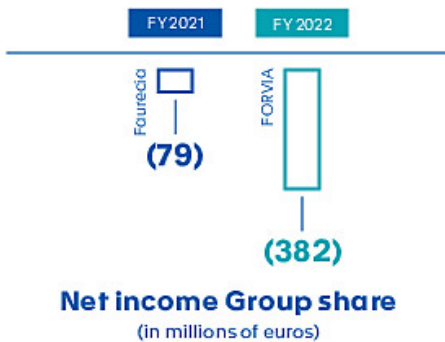
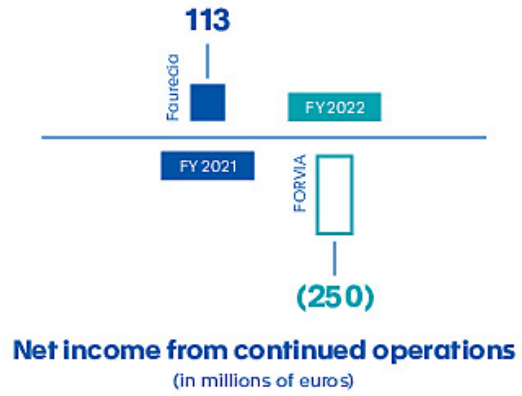
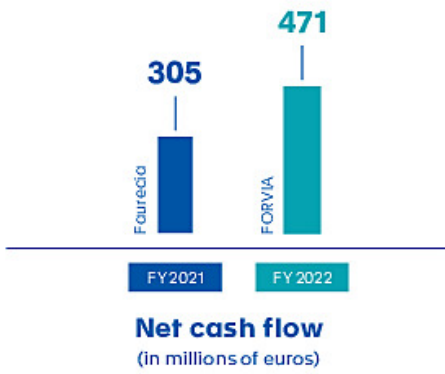
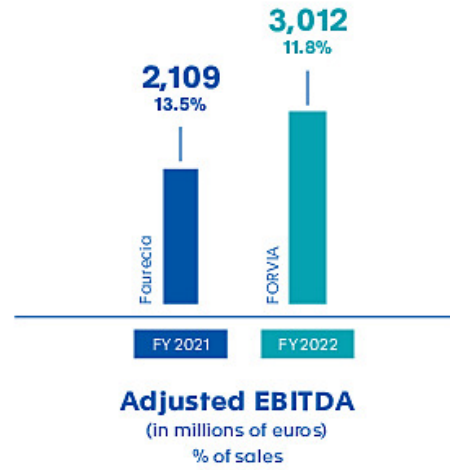
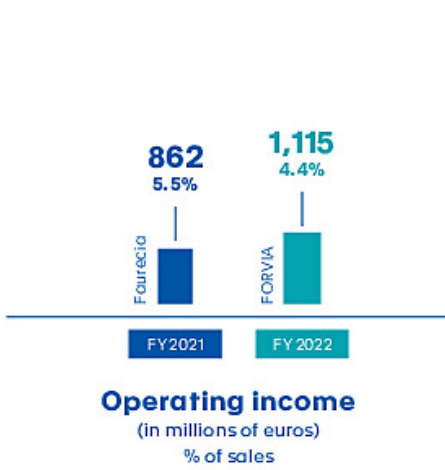

Governance and performance

# 2022 sustainability performance

 <b>Planet</b> Care for the planet	 <b>Business</b> Perform in a responsible way	 <b>People</b> Contribute to society
---	--	---

**Our key 2022 indicators**

<p><b>CO<sub>2</sub> EMISSIONS</b>                  0.83 metric tons of CO<sub>2</sub>eq (Scopes 1 &amp; 2)                  12 metric tons of CO<sub>2</sub>eq (scopes 1,2,3 - controlled emissions, excluding product usage)</p> <p><b>CO<sub>2</sub> INTENSITY</b>                  33 tons of CO<sub>2</sub>eq scopes 1 &amp; 2 / € million sales</p> <p><b>ENERGY INTENSITY</b>                  101 MWh scopes 1 &amp; 2 / € million sales</p> <p><b>WASTE INTENSITY</b>                  9.15 tons waste / € million sales</p> <p><b>WATER INTENSITY</b>                  126.3 m<sup>3</sup> / € million sales</p> <p><b>GREEN TAXONOMY</b>                  21.5% share of revenues aligned</p>	<p><b>BUSINESS ETHICS</b>                  96.7%* of employees trained on the Code of Ethics</p> <p><b>RESPONSIBLE SUPPLY CHAIN</b>                  77%* of supplier panel assessed by EcoVadis                  40/100* minimum score for suppliers assessed by EcoVadis</p> <p><b>SAFETY AT WORK</b>                  2.08 accidents with &amp; without stoppage per million hours worked</p>	<p><b>DIVERSITY</b>                  23%* women among the Top 300 leaders                  27.3% women among managers and skilled professionals</p> <p><b>LEARNING ORGANIZATION</b>                  22.9* hours of training per employee per year</p>
--	--	--

**FORVIA sustainability roadmap**

<b>By 2025</b>	<p><b>CO<sub>2</sub> neutral</b> in operations scopes 1 &amp; 2</p> <p>-28% in waste intensity</p>	<p><b>BUSINESS ETHICS</b>                  100% of employees trained in the Code of Ethics</p> <p><b>RESPONSIBLE SUPPLY CHAIN</b>                  95% of supplier panel assessed by EcoVadis                  55/100 minimum score for suppliers assessed by EcoVadis</p>	
<b>By 2027</b>	<p>-34% in waste intensity</p>	<p><b>SAFETY AT WORK</b>                  1.5 accidents with &amp; without stoppage per million hours worked</p>	<p><b>DIVERSITY</b>                  25% women among the Top 300 leaders                  30% women among managers and skilled professionals</p>
<b>By 2030</b>	<p>-45% in CO<sub>2</sub> emissions scopes 1, 2, 3</p>		<p><b>DIVERSITY</b>                  30% women among the Top 300 leaders                  35% women among managers and skilled professionals</p> <p><b>LEARNING ORGANIZATION</b>                  25 hours of training per employee per year</p>
<b>By 2045</b>	<p><b>CO<sub>2</sub> net zero</b></p>		



## 1 Financial and accounting information

[previous](#)